



MODEL NO : TM080SDH01

MODEL VERSION: 41

SPEC VERSION : Ver.1.5

ISSUED DATE: 2017-03-31

- Preliminary Specification
 Final Product Specification

Customer :

Approved by	Notes

TIANMA Confirmed :

Prepared by	Checked by	Approved by
Bin_Wang	Longpin_Deng	Minhong_Kim

This technical specification is subjected to change without notice



Table of Contents

Table of Contents	2
Record of Revision.....	3
1 General Specifications	4
2 Input/Output Terminals	5
3 Absolute Maximum Ratings	7
4 Electrical Characteristics	8
5 Timing Chart.....	11
6 Optical Characteristics.....	14
7 Environmental / Reliability Test.....	17
8 Mechanical Drawing.....	18
9 Packing drawing.....	19
10 Precautions for Use of LCD Modules	20

TIANMA CONFIDENTIAL



1 General Specifications

Feature		Spec
Display Spec.	Size	8 inch
	Resolution	800(RGB) x 600
	Technology Type	a-Si
	Pixel Configuration	R.G.B. Vertical Stripe
	Pixel pitch(mm)	0.2025(H) x 0.2025 (V)
	Display Mode	TM with Normally White
	Surface Treatment	Anti Glare
	Viewing Direction	12 o'clock
	Gray Scale Inversion Direction	6 o'clock
Mechanical Characteristics	LCM (W x H x D) (mm)	183.0(W)x141.0(H)x5.6(D)
	Active Area(mm)	162.0 (W) x121.5 (H)
	With /Without TSP	Without TSP
	Matching Connection Type	CN1:FH12A-50S-0.5H CN2:35001-HS-02
	LED Numbers	27LEDs
	Weight (g)	225 ± 5%
Electrical Characteristics	Interface	RGB 24bits with TCON
	Color Depth	16.7
	Driver IC	HX8282*1+HX8696*1

Note 1: Viewing direction for best image quality is different from TFT definition. There is a 180 degree shift.

Note 2: Requirements on Environmental Protection: Q/S0002

Note 3: LCM weight tolerance: +/- 5%



2 Input/Output Terminals

2.1 CN1 of FPC

Matching Connector of FH12A-50S-0.5H

Pin No.	Symbol	I/O	function	Remarks
1	NC	-	No connection	
2	NC	-	No connection	
3	NC	-	No connection	
4	NC	-	No connection	
5	GND	P	Power ground	
6	VCOM	I	Common voltage	
7	VCC	P	Power supply 3.3V	
8	MODE	I	DE/SYNC mode select	MODE=1, DE mode; MODE=0, HSD/VSD mode.
9	DE	I	Data input enable	
10	VS	I	Vertical syncinput	
11	HS	I	Horizontal sync Input	
12	B7	I	Blue data(MSB)	
13	B6	I	Blue data	
14	B5	I	Blue data	
15	B4	I	Blue data	
16	B3	I	Blue data	
17	B2	I	Blue data	
18	B1	I	Blue data	
19	B0	I	Blue data(LSB)	
20	G7	I	Green data(MSB)	
21	G6	I	Green data	
22	G5	I	Green data	
23	G4	I	Green data	
24	G3	I	Green data	
25	G2	I	Green data	
26	G1	I	Green data	
27	G0	I	Green data(LSB)	
28	R7	I	RED data(MSB)	

The information contained herein is the exclusive property of Shanghai Tianma Micro-electronics Corporation, and shall not be distributed, reproduced, or disclosed in whole or in part without prior written permission of Shanghai Tianma Micro-electronics Corporation.



29	R6	I	RED data	
30	R5	I	RED data	
31	R4	I	RED data	
32	R3	I	RED data	
33	R2	I	RED data	
34	R1	I	RED data	
35	R0	I	RED data(LSB)	
36	GND	P	Power ground	
37	DCLK	I	Clock for input data	
38	GND	P	Power ground	
39	L/R	I	Left/right scan selection	L/R=1,from left to right; L/R=0, from right to left.
40	U/D	I	Up/down selection	U/D=0,from up to down; U/D=1,from down to up.
41	VGH	P	Gate on voltage	
42	VGL	P	Gate off voltage	
43	AVDD	P	Power for analog circuit	
44	RESET	I	Global reset pin	
45	NC	-	No connection	
46	VCOM	I	Common voltage	
47	DITHB	I	Dithering function	DITHB=0,Disable internal dithering function; DITHB=1,Enable internal dithering function
48	GND	P	Power ground	
49	NC	-	No connection	
50	NC	-	No connection	

Note: I/O definition.

I---Input pin, O---Output pin, P--- Power/Ground, N--- No Connection

2.2 CN2 of LED BLU Connector

Matching Connector of 35001-HS-02

Pin	Symbol	I/O	Description	Remark
1	LED+	P	LED Anode	
2	LED-	P	LED Cathode	

The information contained herein is the exclusive property of Shanghai Tianma Micro-electronics Corporation, and shall not be distributed, reproduced, or disclosed in whole or in part without prior written permission of Shanghai Tianma Micro-electronics Corporation.



3 Absolute Maximum Ratings

AGND= GND=0V, Ta = 25°C

Item	Symbol	Min	Max	Unit	Remark
Power Voltage	VCC	-0.5	3.96	V	
	AVDD	-0.5	14.85	V	
	VGH	-0.3	+42	V	
	VGL	VGH-42	+0.3	V	
Input voltage	V _{IN}	-0.5	3.96	V	Note 1
Backlight Forward Current	I _{LED}	-	25	mA	For each LED
Operating Temperature	T _{OPR}	-20	70	°C	
Storage Temperature	T _{STG}	-30	80	°C	
Relative Humidity Note2	RH	--	≤95	%	Ta≤40°C
		--	≤85	%	40°C < Ta≤50°C
		--	≤55	%	50°C < Ta≤60°C
		--	≤36	%	60°C < Ta≤70°C
		--	≤24	%	70°C < Ta≤80°C
Absolute Humidity	AH	--	≤70	g/m ³	Ta>70°C

Note1: Input voltage include R0~R7, G0~G7, B0~B7, DCLK, HS, VS, MODE, DE, L/R, U/D, RESET, DITHB.

Note2: Ta means the ambient temperature.

It is necessary to limit the relative humidity to the specified temperature range.
Condensation on the module is not allowed.



4 Electrical Characteristics

4.1 Recommended Operating Condition

AGND=GND=0V, Ta = 25°C

Item	Symbol	Min	Typ	Max	Unit	Remark
Power Voltage	VCC	2.8	3.3	3.6	V	Digital Supply Voltage
	AVDD	12.4	12.6	12.8	V	Analog Supply Voltage
	VGH	20	22	24	V	Gate On Voltage
	VGL	-7.4	-6.9	-6.4	V	Gate Off Voltage
	VCOM	4.05	4.1	4.15	V	Common Electrode Driving Signal
Input voltage Note1	V _{IH}	0.7VCC		VCC		High Level
	V _{IL}	0		0.3VCC		Low Level

Note1: Input voltage include R0~R7, G0~G7, B0~B7, DCLK, HS, VS, MODE, DE, L/R, U/D, RESET, DITHB.

Note2: The value is for design stage only.



4.2 Recommended Driving Condition for Backlight

Ta=25°C

Item	Symbol	Min	Typ	Max	Unit	Remark
Forward Current	I_F	-	180	225	mA	27 LEDs (3 LED Serial, 9 LED Parallel)
Forward Voltage	V_F	9	9.6	10.3	V	
Backlight Power Consumption	W_{BL}	-	1.73	2.32	W	
Operating Life Time	-	20,000	25,000	-	Hrs	$I_{LED} = 20mA$

Note1: For each LED: $I_{LED} = 20mA$, $V_{LED} = 3.2V$.

Note2: Under LCM operating, the stable forward current should be inputted. And forward voltage is for reference only.

Note3: I_F is defined for LED Module. Optical performance should be evaluated at Ta=25°C only if LED is driven by high current, high ambient temperature & humidity condition. The life time of LED will be reduced. Operating life means brightness goes down to 50% initial brightness. Typical operating life time is estimated data.

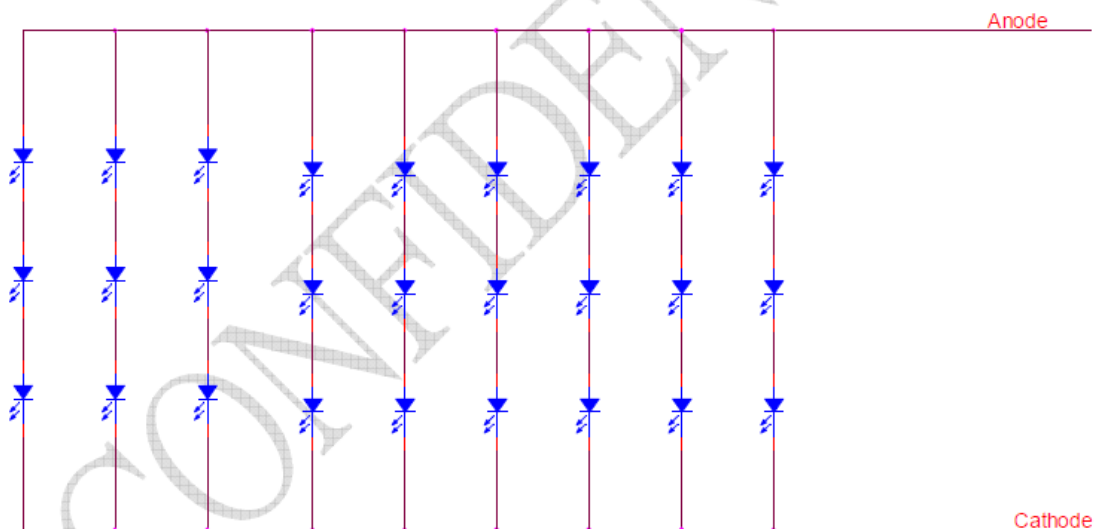



4.3 Power Consumption

AGND=GND=0V, Ta = 25°C

Item	Symbol	Condition	Min	Typ	Max	Unit	Remark
Digital Supply Current	I _{VCC}	VCC=3.3V	3.1	6.5	10	mA	
Power Consumption	Panel&Gamma		-	0.50	0.59	W	
	Backlight		-	1.73	2.32	W	
	Total		-	2.23	2.91	W	

4.4 Block Diagram

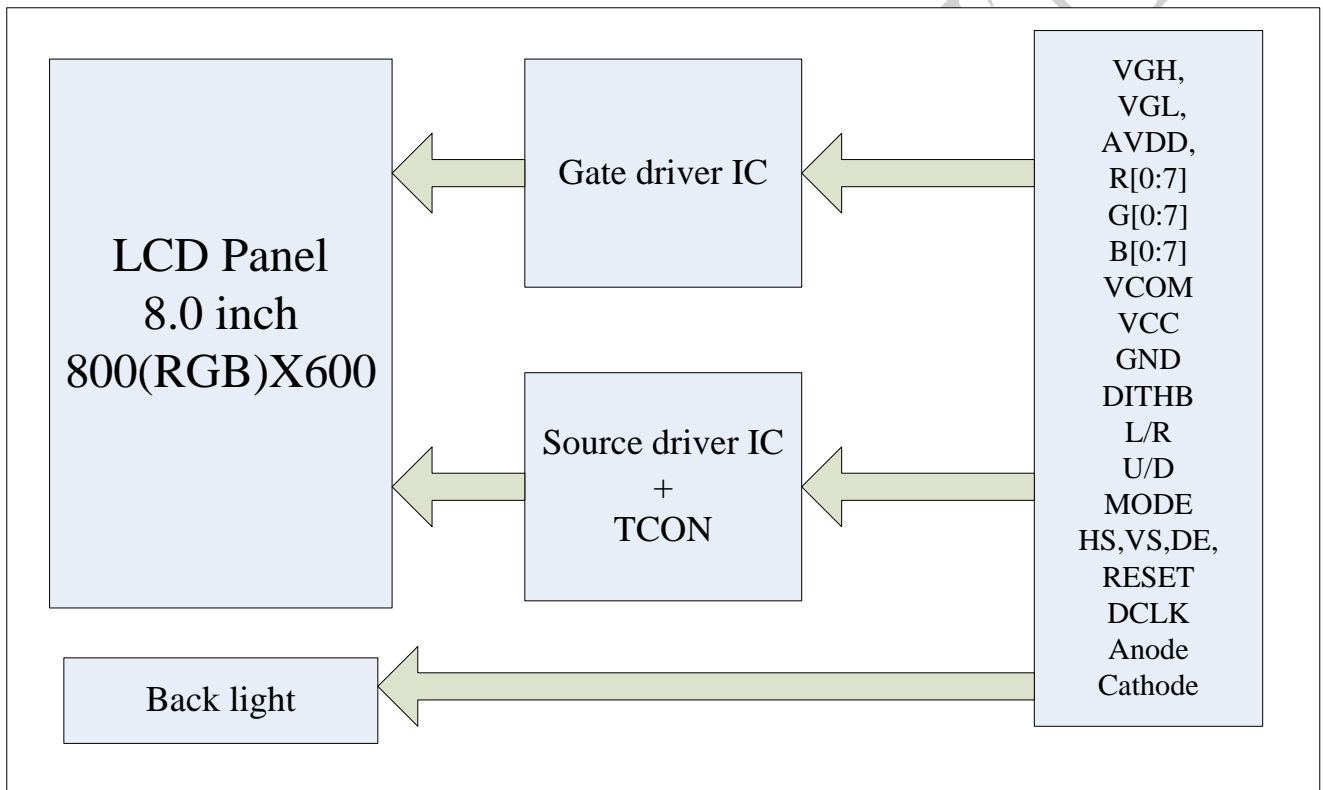



5 Timing Chart

5.1 TFT-LCD Input Timing

VCC=3.3V, AVDD=12.6V, AGND=GND=0V, Ta=25°C

Parameter	Symbol	Min	Typ	Max	Unit	Conditions
VDD Power On Slew rate	TPOR	-	-	20-	ms	From 0V to 90% VDD
GRB pulse width	T _{GRB}	50	-	-	us	DCLK=65MHz
DCLK Cycle Time	T _{cph}	14			ns	
DCLK Pulse Duty	T _{cwh}	40	50	60	%	
VSD Setup Time	T _{vst}	5	-	-	ns	
VSD Hold Time	T _{vhd}	5	-	-	ns	
HSD Setup Time	T _{hst}	5	-	-	ns	
HSD Hold Time	T _{hhd}	5	-	-	ns	
Data Setup Time	T _{dsu}	5	-	-	ns	Data to DCLK
Data Hold Time	T _{dhd}	5	-	-	ns	Data to DCLK
DE Setup Time	T _{esu}	5	-	-	ns	
DE Hold Time	T _{ehd}	5	-	-	ns	

Input Clock and Data timing Diagram:

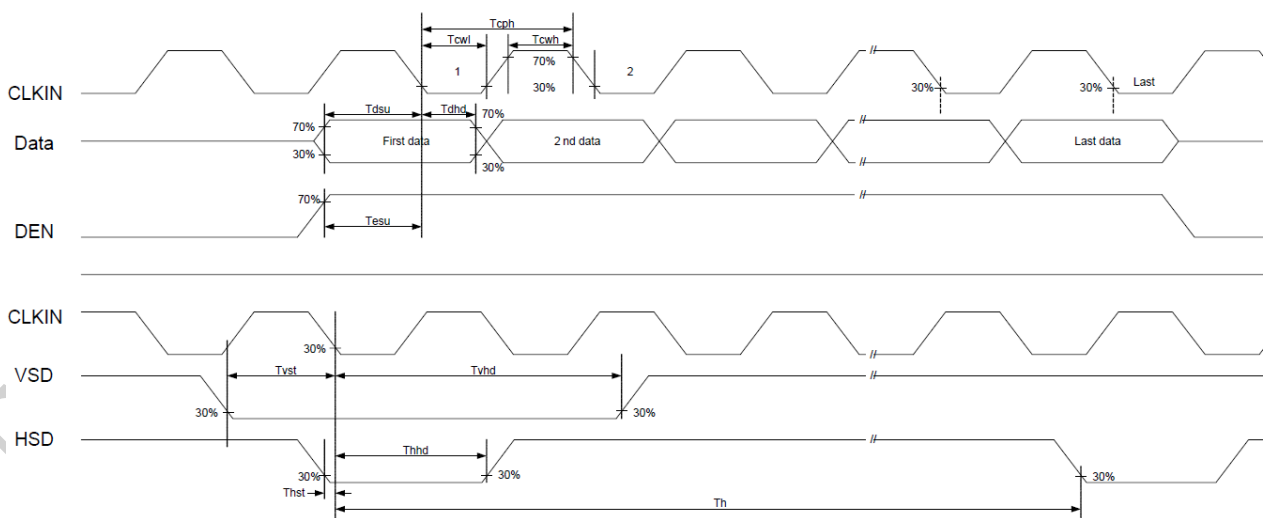

The information contained herein is the exclusive property of Shanghai Tianma Micro-electronics Corporation, and shall not be distributed, reproduced, or disclosed in whole or in part without prior written permission of Shanghai Tianma Micro-electronics Corporation.



5.2 Recommended Timing Setting Of TCON

TCON (Embedded In Source IC) Input Timing (DCLK, HSD, VSD, DE)

VCC=3.3V, AVDD=12.6V, AGND=GND=0V, Ta=25°C

Parameter	Symbol	Min	Typ	Max	Unit	Remark
DCLK	Fclk	34.5	39.6	50.4	MHZ	
	tclk		25.3		ns	
HSD	th	900	1000	1200	DCLK	
	thd	-	800	-	DCLK	
	thpw	1	-	40	DCLK	
	thbp	-	88	-	DCLK	
	thfp	12	112	312	DCLK	
VSD	tv	640	660	700	th	
	tvd	-	600	-	th	
	tvpw	1	-	20	th	
	tvbp	-	39	-	th	
	tvfp	1	21	61	th	

Note: DE timing refer to HSD, VSD input timing.

Vertical input timing Diagram:

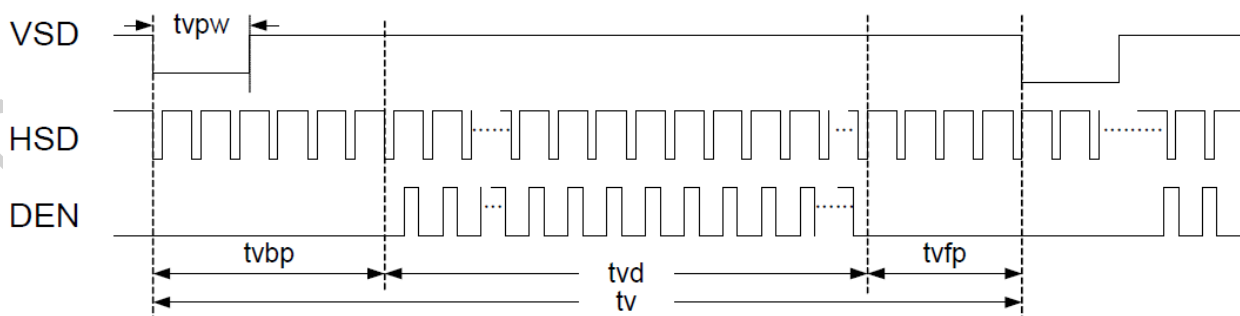

The information contained herein is the exclusive property of Shanghai Tianma Micro-electronics Corporation, and shall not be distributed, reproduced, or disclosed in whole or in part without prior written permission of Shanghai Tianma Micro-electronics Corporation.



Horizontal input timing Diagram:

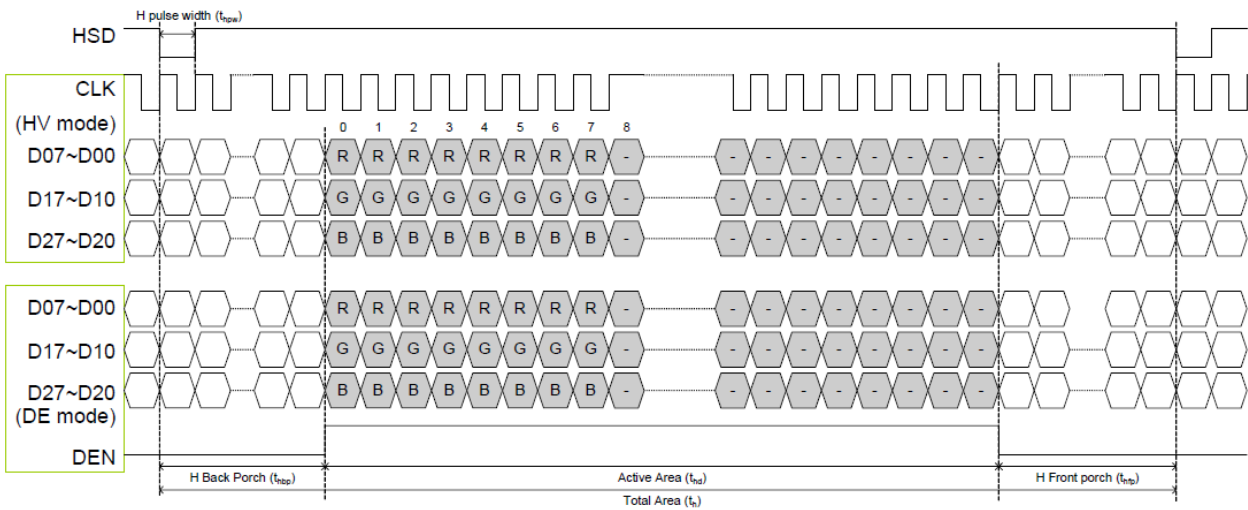

5.3 POWER ON/OFF SEQUENCE

Item	Symbol	Min	Typ	Max	Unit	Remark
VCC 3.3V rising time	T1	0	-	20	ms	
VCC to AVDD on time	T2	16.7	-	-	ms	
AVDD to VGL on time	T3	0	-	-	ms	
VGL to VGH on time	T4	0	-	-	ms	
VGH to DATA on time	T5	0	-	-	ms	
DATA to BL on time	T6	0	-	-	ms	

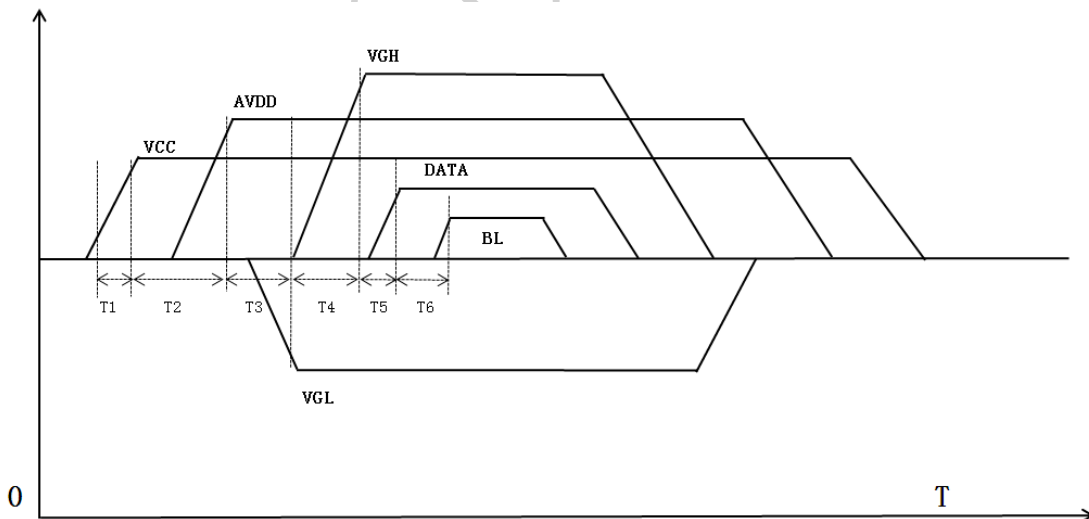

- Note:
1. Power on sequence: VCC → AVDD → VGL → VGH → DATA ON → BACKLIGHT ON
 2. Power off sequence: BACKLIGHT OFF → DATA OFF → VGH → VGL → AVDD → VCC
 3. When VCC turned on, the rising time T1 should less than 20ms.
 4. AVDD stable to VCC stable time T2 should better longer than 1 frame time.
 5. The power off sequence can be set according to power on settings.

The information contained herein is the exclusive property of Shanghai Tianma Micro-electronics Corporation, and shall not be distributed, reproduced, or disclosed in whole or in part without prior written permission of Shanghai Tianma Micro-electronics Corporation.



6 Optical Characteristics

Ta=25°C

Item	Symbol	Condition	Min	Typ	Max	Unit	Remark
View Angles	θT	$CR \geq 10$	50	60	-	Degree	Note 2,3
	θB		60	70	-		
	θL		60	70	-		
	θR		60	70	-		
Contrast Ratio	CR	$\theta=0^\circ$	600	800	-		Note3
Response Time	T_{ON}	25°C	-	20	30	ms	Note4
	T_{OFF}						
Chromaticity	White	x	0.253	0.303	0.353		Note1 Note5
		y	0.257	0.307	0.357		
	Red	x	0.525	0.575	0.625		
		y	0.296	0.346	0.396		
	Green	x	0.298	0.348	0.398		
		y	0.527	0.577	0.627		
	Blue	x	0.101	0.151	0.201		
		y	0.031	0.081	0.131		
Uniformity	U		70	75	-	%	Note6
NTSC			45	50	-	%	Note 5
Luminance	L		200	250	-	cd/m ²	Note7

Test Conditions:

1. $I_{LED} = 20mA$, and the ambient temperature is 25°C.
2. The test systems refer to Note 1 and Note 2.



Note 1: Definition of optical measurement system.

The optical characteristics should be measured in dark room. After 5 Minutes operation, the optical properties are measured at the center point of the LCD screen. All input terminals LCD panel must be ground when measuring the center area of the panel.

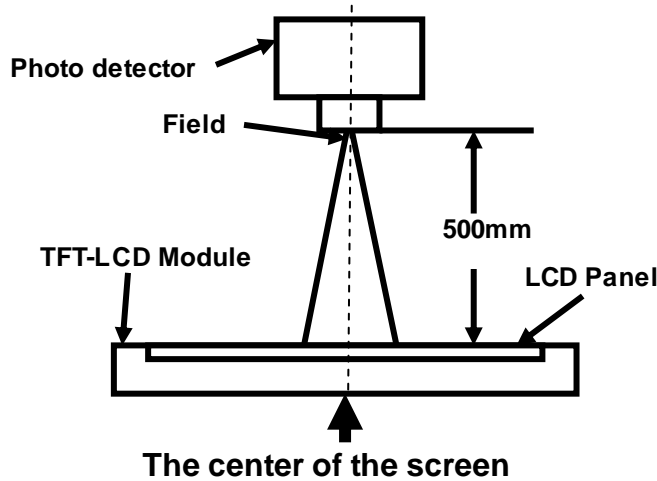

Note 2: Definition of viewing angle range and measurement system.

viewing angle is measured at the center point of the LCD by CONOSCOPE(ergo-80).

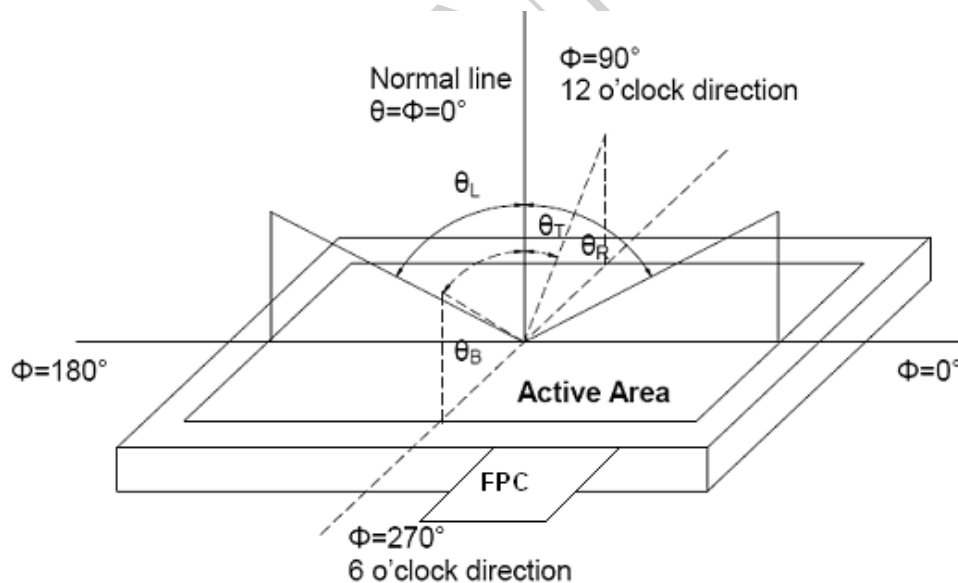

Note 3: Definition of contrast ratio

$$\text{Contrast ratio (CR)} = \frac{\text{Luminance measured when LCD is on the "White" state}}{\text{Luminance measured when LCD is on the "Black" state}}$$

“White state “: The state is that the LCD should drive by V_{white}.

“Black state”: The state is that the LCD should drive by V_{black}.

V_{white}: To be determined V_{black}: To be determined.

Note 4: Definition of Response time

The information contained herein is the exclusive property of Shanghai Tianma Micro-electronics Corporation, and shall not be distributed, reproduced, or disclosed in whole or in part without prior written permission of Shanghai Tianma Micro-electronics Corporation.



The response time is defined as the LCD optical switching time interval between “White” state and “Black” state. Rise time (T_{ON}) is the time between photo detector output intensity changed from 90% to 10%. And fall time (T_{OFF}) is the time between photo detector output intensity changed from 10% to 90%.

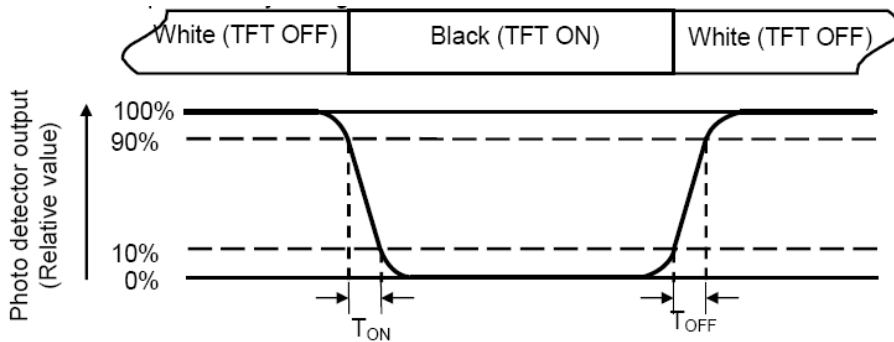

Note 5: Definition of color chromaticity (CIE1931)

Color coordinates measured at center point of LCD.

Note 6: Definition of Luminance Uniformity

Active area is divided into 9 measuring areas (Refer Fig. 2). Every measuring point is placed at the center of each measuring area.

$$\text{Luminance Uniformity (U)} = L_{\min} / L_{\max}$$

L-----Active area length W----- Active area width

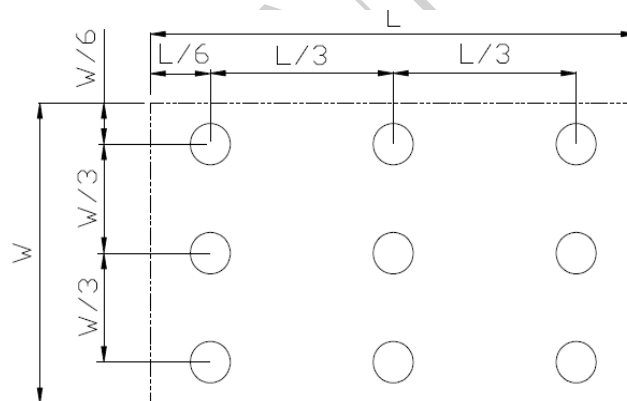

L_{\max} : The measured Maximum luminance of all measurement position.

L_{\min} : The measured Minimum luminance of all measurement position.

Note 7: Definition of Luminance:

Measure the luminance of white state at center point.



7 Environmental / Reliability Test

No	Test Item	Condition	Remarks
1	High Temperature Operation	Ts = +70°C , 240 hours (Note1)	IEC60068-2-1:2007 GB2423.2-2008
2	Low Temperature Operation	Ta = -20°C , 240 hours (Note2)	IEC60068-2-1:2007 GB2423.1-2008
3	High Temperature Storage	Ta = +80°C , 240 hours	IEC60068-2-1:2007 GB2423.2-2008
4	Low Temperature Storage	Ta = -30°C , 240 hours	IEC60068-2-1:2007 GB2423.1-2008
5	Storage at High Temperature and Humidity	Ta = +60°C , 90% RH max,240hours	IEC60068-2-78 :2001 GB/T2423.3—2006
6	Thermal Shock (non-operation)	-30°C 30 min~+80°C 30 min, Change time:5min, 20 Cycle	Start with cold temperature, End with high temperature, IEC60068-2-14:1984,G B2423.22-2002
7	ESD	C=150pF,R=330Ω,5point/panel Air:±8Kv,5times; Contact:±4Kv,5times (Environment:15°C~35°C, 30%~60%.86Kpa~106Kpa)	IEC61000-4-2:2001 GB/T17626.2-2006
8	Vibration Test	Frequency range:10~55Hz Stroke:1.5mm Sweep:10Hz~55Hz~10Hz 2 hours for each direction of X.Y.Z. (6 hours for total)	IEC60068-2-6:1982 GB/T2423.10—1995
9	Mechanical Shock (Non Op)	Half Sine Wave 60G 6ms, ±X,±Y,±Z 3times for each direction	IEC60068-2-27:1987 GB/T2423.5—1995
10	Package Drop Test	Height: 80cm, 1corner,3edges,6surfaces	IEC60068-2-32:1990 GB/T2423.8—1995

Note1: Ts is the temperature of panel's surface.

Note2: Ta is the ambient temperature of samples.

Note3: Before cosmetic and function test, the product must have enough recovery time, at least 2 hours at room temperature.

Note4: In the standard condition, there shall be no practical problem that may affect the display function. After the reliability test, the product only guarantees operation, but don't guarantee all of the cosmetic specification.



9 Packing drawing

No	Item	Model (Material)	Dimensions(mm)	Unit Weight(Kg)	Quantity	Remark														
1	LCM module	TM080SDH01-41	183.0X141.0X5.6	0.225	48															
2	Partition_1	Corrugated paper	527X348X217	1.571	1															
3	Anti-static Bag	PE	161X253X0.05	0.001	48	Anti-static														
4	Dust-Proof Bag	PE	700X545	0.06	1															
5	Partition_2	Corrugated Paper	505X332X4.0	0.098	2															
6	Corrugated Bar	Corrugated paper	348X173	6		7	Carton	Corrugated paper	544X365X250	1.12	1		8	Total weight	14.137±5%					
7	Carton	Corrugated paper	544X365X250	1.12	1															
8	Total weight	14.137±5%																		

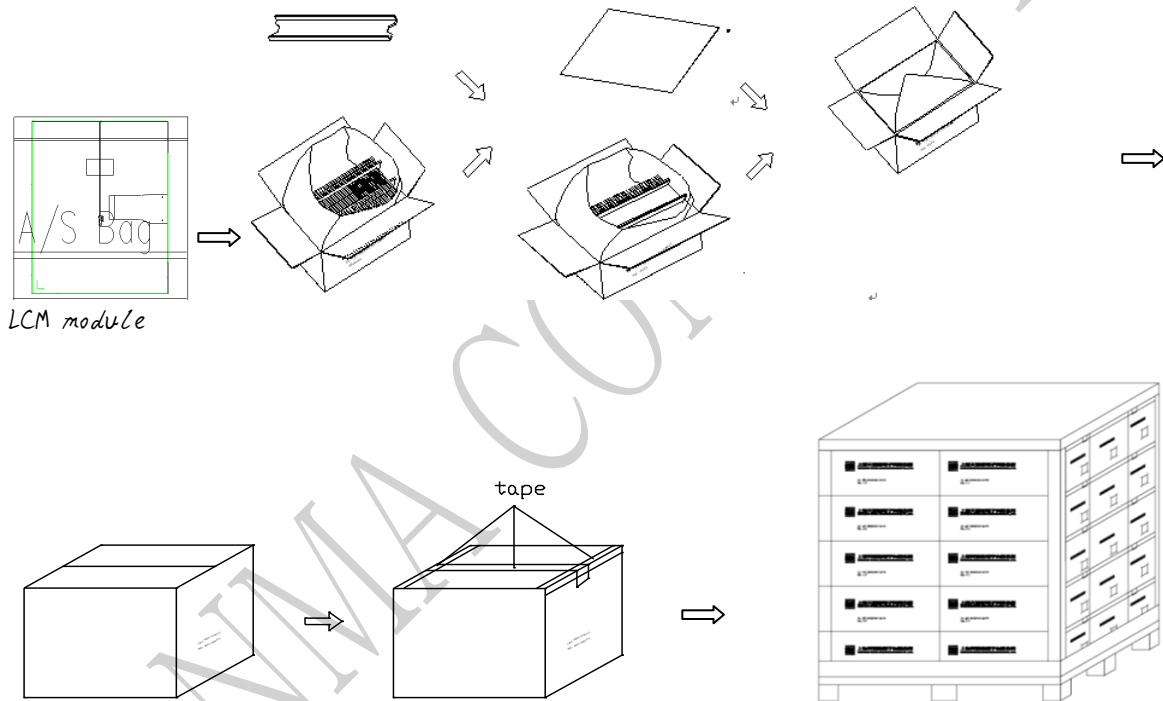

The information contained herein is the exclusive property of Shanghai Tianma Micro-electronics Corporation, and shall not be distributed, reproduced, or disclosed in whole or in part without prior written permission of Shanghai Tianma Micro-electronics Corporation.



10 Precautions for Use of LCD Modules

10.1 Handling Precautions

10.1.1 The display panel is made of glass. Do not subject it to a mechanical shock by dropping it from a high place, etc.

10.1.2 If the display panel is damaged and the liquid crystal substance inside it leaks out, be sure not to get any in your mouth, if the substance comes into contact with your skin or clothes, promptly wash it off using soap and water.

10.1.3 Do not apply excessive force to the display surface or the adjoining areas since this may cause the color tone to vary.

10.1.4 The polarizer covering the display surface of the LCD module is soft and easily scratched. Handle this polarizer carefully.

10.1.5 If the display surface is contaminated, breathe on the surface and gently wipe it with a soft dry cloth. If still not completely clear, moisten cloth with one of the following solvents:

- Isopropyl alcohol
- Ethyl alcohol

Solvents other than those mentioned above may damage the polarizer. Especially, do not use the following:

- Water
- Ketone
- Aromatic solvents

10.1.6 Do not attempt to disassemble the LCD Module.

10.1.7 If the logic circuit power is off, do not apply the input signals.

10.1.8 To prevent destruction of the elements by static electricity, be careful to maintain an optimum work environment.

10.1.8.1 Be sure to ground the body when handling the LCD Modules.

10.1.8.2 Tools required for assembly, such as soldering irons, must be properly ground.

10.1.8.3 To reduce the amount of static electricity generated, do not conduct assembly and other work under dry conditions.

10.1.8.4 The LCD Module is coated with a film to protect the display surface. Be care when peeling off this protective film since static electricity may be generated.

10.2 Storage precautions

10.2.1 When storing the LCD modules, avoid exposure to direct sunlight or to the light of fluorescent lamps.

10.2.2 The LCD modules should be stored under the storage temperature range. If the LCD modules will be stored for a long time, the recommend condition is:

Temperature : 0°C ~ 40°C , Relatively humidity: ≤80%

10.2.3 The LCD modules should be stored in the room without acid, alkali and harmful gas.

10.3 Transportation Precautions

10.3.1 The LCD modules should be no falling and violent shocking during transportation, and also should avoid excessive press, water, damp and sunshine.